

FISHER  
FISHER  
FISHER  
FISHER  
FISHER  
FISHER  
FISHER  
FISHER



# FISHER

*Studio-Standard*

FISHER  
FISHER  
FISHER  
FISHER  
FISHER  
FISHER  
FISHER  
FISHER  
**FISHER ...**  
FISHER

**OPERATING INSTRUCTIONS**

# MT-6310

**MT-6310C**

**DC SERVO  
BELT DRIVE TURNTABLE**

*THE FIRST NAME IN HIGH FIDELITY*

NOTE: Locate turntable's serial number (shown on rear panel of unit) and record it here → \_\_\_\_\_



# FISHER

# MT-6310

## SPECIFICATIONS

Motor	DC Servo
Drive System	Belt
Wow & Flutter (WRMS)	0.04 %
Rumble (DIN 45539B)	-68 dB
Speed Variation	±0.8 %
Speed Control Range	±3 %
Tracking Force Range	0.6 – 3.5 grams
Tracking Force Adjustment	Calibrated Counterweight
Platter Diameter	12-3/8"
Platter Weight	2.2 lbs.
Strobe Light	Yes
Record Speed Selector	33/45 rpm
Auto Function	
Stop	Yes
Reject	Yes
Automatic	
Tone Arm Return at End of Record	Yes
Manual Function	
Start	Yes
Stop	Yes
Tone Arm Data	
Resonance	<10 Hz
Balance Adjustment	Counterweight
Effective Length	222 mm
Shape	S-Form
Bearing Type	
Horizontal	Thrust
Friction Sensitivity	0.2 gram
Vertical	Pivot
Friction Sensitivity	0.25 gram
Max. Tracking Error	±2.0°
Anti-Skate Control	Calibrated Adjustable
Cueing	Viscous Damped
Overhang Indicator	Yes
Cartridge Supplied	Model MT-6310C Stereo Magnetic (MG-44)
<b>GENERAL</b>	120 V AC ±10 %
Power Requirements	50/60 Hz 4 Watts
Dimensions (WxDxH)	17-5/16" x 14-15/16" x 5-7/16"
Weight (approx.)	10.2 lbs.

\* Specifications are subject to change without notice.

**IMPORTANT . . .** This highly sophisticated turntable was developed by FISHER to give you many years of listening enjoyment.

Please read the following instructions carefully. They were prepared to assist you during the initial set-up and to ensure ultimate performance of the turntable at all times.

**THE WARRANTY ON THIS UNIT DOES NOT COVER DAMAGE CAUSED BY MISHANDLING OR MISUSE.**

**WARNING:** To avoid the hazard of fire or electrical shock, do not expose this turntable to rain or other moisture.

## UNPACKING THE UNIT

- 1 Carefully unpack the unit, the 45 rpm adapter which is packed separately in a plastic bag, the counterweight and cartridge shell which are packed in padding and the rubber mat and trim ring plate which are packed separately in plastic bags.
- 2 Remove the three screws that hold the turntable platter in place during shipment. (Fig. 1)

It is advisable to retain the carton, padding and the turntable platter shipping screws in case reshipment is necessary.

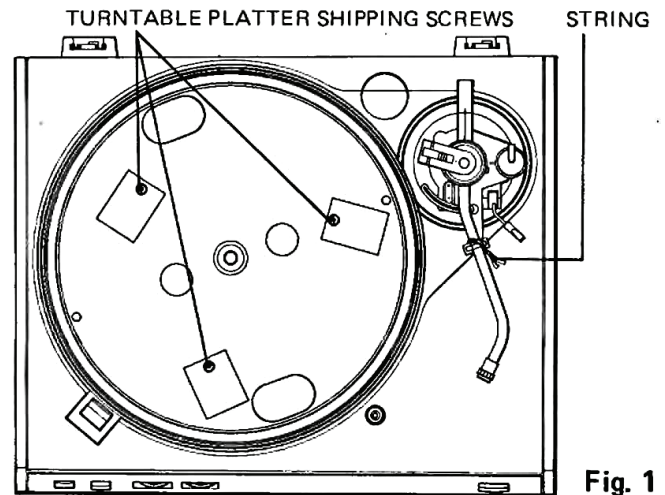

## ASSEMBLING

- 1 Remove the turntable platter by pulling straight up.
- 2 Align the non-serrated section of the drive gear until it faces the turntable shaft. (Fig. 2)
- 3 Check that the belt is mounted on the belt flange of the turntable platter and then slip the turntable platter over the turntable shaft.
- 4 Rotate the turntable platter until the pulley is visible. Put the drive belt (which is seated on the turntable drive rim) onto the pulley. (Fig. 3) Make sure that the belt is not twisted.
- 5 Place the rubber mat and the trim ring plate onto the turntable platter.
- 6 Rotate the cartridge shell ring of the tone arm and attach the cartridge shell.
- 7 Screw the counterweight onto the end of the tone arm to mount. (Fig. 4)
- 8 Unfasten the string or "twist tab" wire that secures the tone arm during shipment. (Fig. 1)
- 9 Remove the stylus cover.

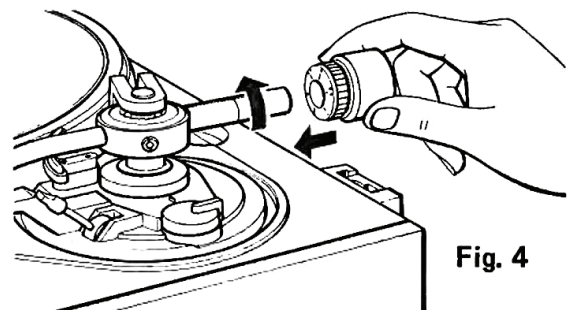
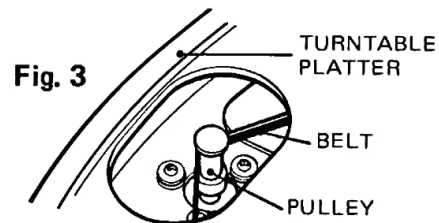
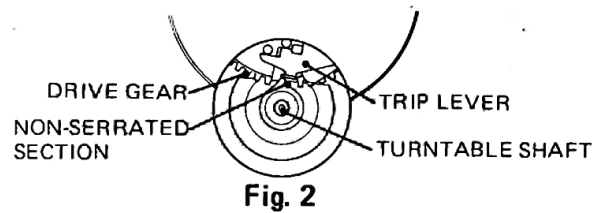

## IMPORTANT . . .

When putting belt on pulley, the portion of the drive belt running around the belt flange of the turntable platter should be placed uniformly in the middle of the flange. (Fig. 5)

Unless the belt is kept level it may run off the flange.

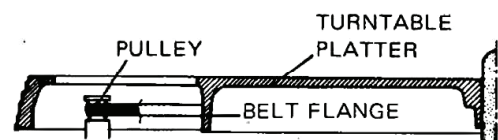

## TONE ARM BALANCING and TRACKING FORCE ADJUSTMENT

The tone arm should be rebalanced every time you change the cartridge and shell assembly.

- 1 With cartridge and shell installed, release the tone arm from its rest position. Hold the tone arm loosely by the tone arm lift (Fig. 6). Rotate counterweight in either direction until the tone arm starts to rise. Continue adjusting the counterweight until the tone arm floats (balanced) and is parallel to the surface of the platter.
- 2 Hold the tone arm counterweight and set the tracking force indicator dial to the zero position relative to the base line (Fig. 7). The tone arm and cartridge assembly are now correctly balanced.
- 3 To adjust the tracking force, simply rotate the counterweight clockwise until the indicator dial shows the correct tracking force recommended by the manufacturer of your cartridge (Fig. 8).

NOTE: The MT-6310C has a high quality magnetic phono cartridge installed at the factory. The correct tracking force for this cartridge is 2 grams.

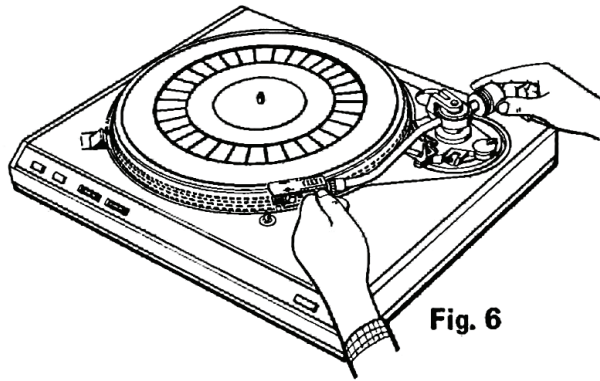

Fig. 6

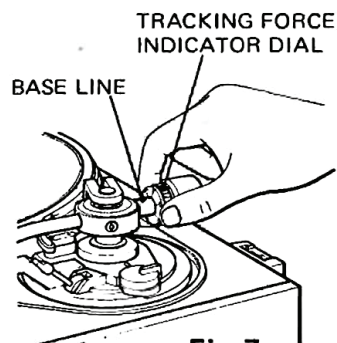

Fig. 7

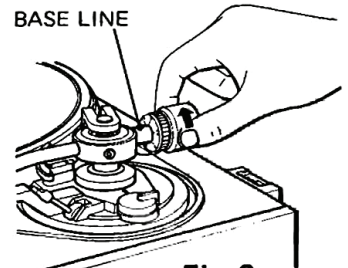

Fig. 8

## ANTI-SKATING ADJUSTMENT

Set the anti-skate control (Fig. 9) to a position which corresponds to the adjusted tracking force. If the cartridge tracking force is 2 grams, the anti-skate control should also be set to 2.

### NOTE:

Adjustment is correct for most spherical styli. For elliptical or SHIBATA type styli it is advisable to adjust the anti-skate control to a position corresponding to 1.2 - 1.4 times the spherical stylus setting.

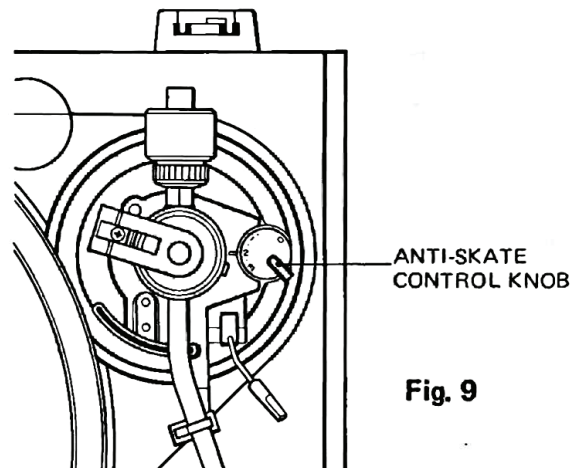

Fig. 9

## CONNECTING THE TURNTABLE

- 1 Connect the two shielded cables coming from the turntable, to the phono input jacks of your amplifier.

- 2 Connect the ground wire to the system ground terminal of your amplifier.
- 3 Connect turntable line cord to an AC outlet (most amplifiers have AC outlets controlled by the amplifier power switch).

## MOUNTING DUST COVER

Fit the hinges of the dust cover into the notches on the rear of the turntable base and then push down. (Fig. 10)

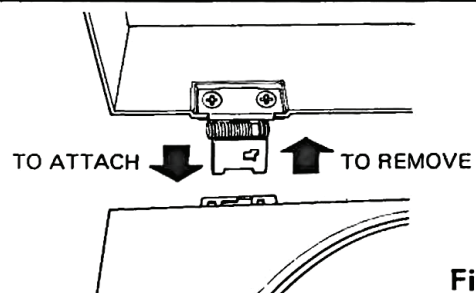

Fig. 10

## ADJUSTMENT OF TURNTABLE SPEED

- 1** Place a 33-1/3 rpm LP on the platter. Push the "33" speed selector button. Move the cueing lever to the UP position. When the tone arm rises, move it over to the lead-in groove of the record. Move the cueing lever to the DOWN position, and the stylus will descend onto the record surface.
- 2** Watch the rows of dots on the platter rim. They can be synchronized by turning the "33" SPEED ADJUST control knob. With perfect synchronization, the dots will appear stationary at the selected speed and power line frequency. There are four rows of dots for speed adjustment. From top to bottom, they are 33-1/3 rpm at a line frequency of 50 Hz, 33-1/3 rpm at 60 Hz, 45 rpm at 50 Hz and 45 rpm at 60 Hz.

- 3** When the dots appear to move in either direction, adjust the speed precisely with the SPEED ADJUST control knob.

Turn the SPEED ADJUST control knob:

- (F) mark . . .the speed will increase
- (S) mark . . .the speed will decrease

The platter is rotating at the correct speed when the dots stand still.

The platter speed should be checked regularly.

When the selected speed is "33" and the power line frequency is 60 Hz, watch the second line of dots from the top. Adjust the speed precisely if the dots appear to move to the right or left.

## IDENTIFICATION OF PARTS AND THEIR FUNCTIONS

- 1** 45 rpm record adapter  
Place this over the turntable spindle when playing 45 rpm records.
- 2** Turntable platter and rubber mat
- 3** Trim ring plate
- 4** Turntable spindle
- 5** Stroboscope
- 6** Speed selector buttons  
"33" . . . . Push this button when playing a 33-1/3 rpm record.  
"45" . . . . Push this button when playing a 45 rpm record.
- 7** SPEED ADJUST control knobs  
Use together with the stroboscope to fine adjust the platter speed.
- 8** Overhang indicator  
This marks point for positioning the stylus.
- 9** REJECT button  
Push this button to stop record play. The tone arm will return to the arm rest automatically.
- 10** Cartridge shell
- 11** Tone arm
- 12** Lock lever
- 13** Arm rest
- 14** Cueing lever (arm lifter)  
Raise this lever and the tone arm will rise. Push the lever down and the tone arm will descend onto the record gently. This control can be used either for starting or interrupting record play.

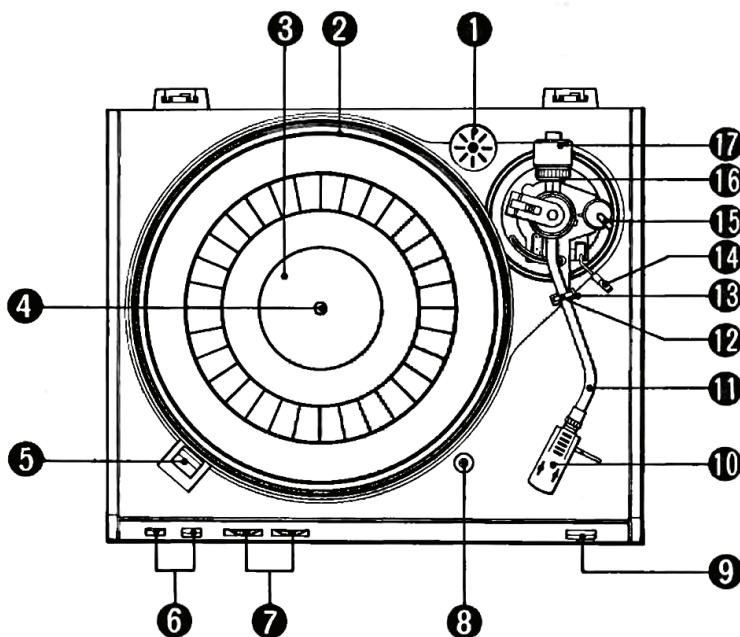

Fig. 11

- 15** Anti-skate control knob  
Use this to adjust the force which prevents the tone arm from skating toward the center of the record.
- 16** Tracking force indicator dial
- 17** Counterweight

## TURNTABLE OPERATION

Turn on your amplifier or receiver. Be sure to turn the VOLUME control to its MINIMUM setting BEFORE operating turntable.

- 1 Place a record on the platter. (If necessary, use the 45 rpm adapter.)
- 2 Select the platter speed by depressing the 33 or 45 button.
- 3 Raise the cueing lever to UP and the tone arm will rise from its rest.  
Move the tone arm over the lead-in groove of the record.
- 4 Move the cueing lever to DOWN and the tone arm will descend gently onto the record and play will begin.
- 5 At the end of the record the tone arm will automatically rise and return to the arm rest.

- To interrupt play. . .  
Move the cueing lever to the UP position and the tone arm will rise from the record.  
Push the cueing lever to DOWN and the tone arm will descend onto the record surface and play will resume.
- To stop play. . .  
Push the REJECT button. This will cause the tone arm to rise and swing back to the rest. The platter will stop rotating as the tone arm descends onto the arm rest.

### NOTE:

DO NOT touch the tone arm while it is returning automatically to the arm rest.

## TROUBLE-SHOOTING GUIDE

Before having your turntable unit serviced, be sure to check the following and make the corrections if possible, according to these suggestions.

SYMPTOM	PROBABLE CAUSE	CORRECTION
<ul style="list-style-type: none"> <li>● Turntable does not rotate.</li> </ul>	<ul style="list-style-type: none"> <li>● Faulty AC power connection.</li> </ul>	<ul style="list-style-type: none"> <li>● Make sure unit is plugged in to "live" AC socket.</li> </ul>
<ul style="list-style-type: none"> <li>● No sound is produced.</li> </ul>	<ul style="list-style-type: none"> <li>● Output cords not connected.</li> <li>● Improper cartridge shell attachment.</li> <li>● Faulty lead wire connections in cartridge.</li> </ul>	<ul style="list-style-type: none"> <li>● Connect cords to amplifier.</li> <li>● Plug cartridge shell into tone arm and fasten it securely.</li> <li>● Re-connect lead wires.</li> </ul>
<ul style="list-style-type: none"> <li>● Noise is audible and there is marked sound distortion in high tonal range.</li> </ul>	<ul style="list-style-type: none"> <li>● Dust accumulation on stylus.</li> <li>● Dusty or scratched disc surface.</li> <li>● Stylus is worn out.</li> <li>● Improper tracking force.</li> <li>● Treble sound excessive.</li> </ul>	<ul style="list-style-type: none"> <li>● Blow dust off, or use stylus brush.</li> <li>● Try a new, clean record.</li> <li>● Replace stylus.</li> <li>● Adjust tracking force.</li> <li>● Adjust tone control.</li> </ul>
<ul style="list-style-type: none"> <li>● Humming sound evident when playing a record.</li> </ul>	<ul style="list-style-type: none"> <li>● Turntable and amplifier are not connected with ground wire.</li> <li>● Faulty connections on output cords.</li> </ul>	<ul style="list-style-type: none"> <li>● Connect turntable and amplifier with ground wire at ground terminals. (In some cases the sound may be better when they are not connected by ground wire.)</li> <li>● Connect output cords to the amplifier correctly.</li> </ul>
<ul style="list-style-type: none"> <li>● Speakers howl when volume is turned up.</li> </ul>	<ul style="list-style-type: none"> <li>● Improper location of turntable in relation to speakers.</li> </ul>	<ul style="list-style-type: none"> <li>● Place turntable on solid surface at a distance from speakers.</li> </ul>

# MAINTENANCE

Remember that your turntable is a sensitive electro-mechanical device that needs occasional maintenance.

- 1** Cleaning the stylus: Dust particles often build up around the stylus. If the build-up becomes excessive it will not only result in noisy reproduction but will eventually shorten the lives of both the record and the stylus. Should this occur, do not remove the dust with your fingers or a tool. Lift the tone arm by its handle and blow the dust away or use a stylus brush.
- 2** Replacing the stylus: To assure distortion-free reproduction, replace the diamond stylus after 1000/2000 LP plays.  
To remove the old stylus, pull out the stylus assembly as in Fig. 12. Replace with a new stylus (available from Fisher Service Center).
- 3** Motor and tone arm drive gear lubrication. . .

**CAUTION: FOR YOUR PERSONAL SAFETY, BE SURE TO DISCONNECT THE A.C. LINE BEFORE YOU PROCEED WITH ANY LUBRICATION AND/OR CLEANING.**

Bearings of rotating and moving parts should be lubricated occasionally with a small amount of low viscosity machine oil.

**CAUTION: DO NOT GET ANY OIL ON THE INSIDE OF THE TURNTABLE, THE DRIVE BELT OR PULLEY. CLEAN THESE PARTS IMMEDIATELY IF NEEDED WITH A CLOTH SATURATED IN ALCOHOL.**

## TO LUBRICATE. . .

- Remove rubber mat and trim ring plate.
- Lift drive belt off pulley.
- Remove turntable platter by pulling straight up.

## TO RE-ASSEMBLE. . .Reverse above procedure.

- 4** Cleaning the dust cover, cabinet and visible metal parts:  
Wipe gently with a soft cloth moistened with luke-warm water. NEVER use benzol, benzine or other strong chemical cleaners since they will damage the finish of your unit. DO NOT allow moisture to penetrate inside of the turntable.

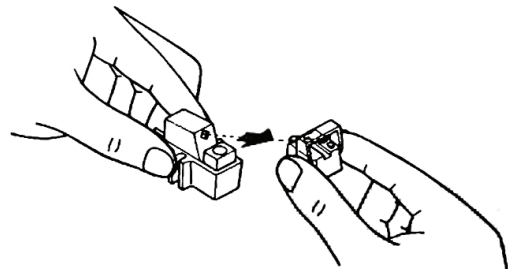

Fig. 12

# MOUNTING THE CARTRIDGE

- 1** Carefully mount the cartridge according to the maker's instructions. DO NOT tighten the mounting screws.
- 2** Connect the 4 colored leads in the cartridge shell to the cartridge terminals.  
Connect properly by matching the colors of the leads and cartridge terminals.  

White	=	Left output
Blue	=	Left ground
Red	=	Right output
Green	=	Right ground
- 3** Plug the cartridge shell into the tone arm and tighten the cartridge shell ring by turning it clockwise. (Fig. 13)
- 4** Move the tone arm over the overhang indicator and adjust cartridge until the stylus point is located exactly above the overhang indicator. Fix cartridge in this location by TIGHTENING the mounting screws. (Fig. 14)  
Be sure to keep the cartridge straight in the cartridge shell.
- 5** Adjust tracking force and anti-skating. (See page 4.)

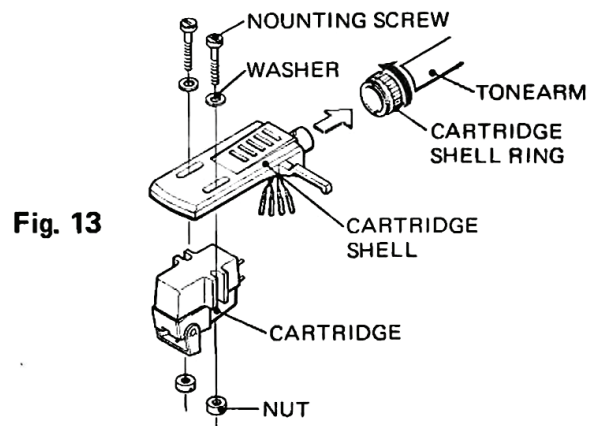

Fig. 13

MT-6310 . . . . . WITHOUT CARTRIDGE  
MT-6310C . . . . . WITH MAGNETIC CARTRIDGE

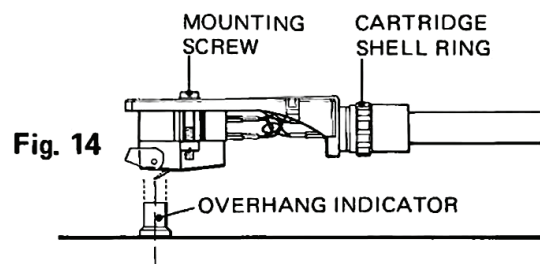

Fig. 14



**FISHER**

*THE FIRST NAME IN HIGH FIDELITY*

*Studio-Standard*

**FISHER CORPORATION, 21314 LASSEN STREET • CHATSWORTH • CALIFORNIA 91311**